

.General Description:

The TTP301A/TTP301B is an one-decimal electronic clinical thermometer IC. It can push switch to select the °C/°F mode.

.Features:

- ✧ Single 1.5V battery power supply
- ✧ Automatic power off function
- ✧ Built-in low voltage detector function
TTP301A : $1.30 \pm 0.05V$
TTP301B : $1.35 \pm 0.05V$
- ✧ Measurement range: $32.0^{\circ}C \sim 42.9^{\circ}C$ ($90.0^{\circ}F \sim 109.9^{\circ}F$)
- ✧ Measurement accuracy: $\pm 0.1^{\circ}C$ ($\pm 0.2^{\circ}F$)
- ✧ Resolution: $0.1^{\circ}C$ ($0.1^{\circ}F$)
- ✧ Highest temperature hold
- ✧ Provide fever alarm function, enable or disable by bonding option
- ✧ Bonding option for memory function
- ✧ Bonding option for stable time selection: 4s/8s/16s/32s
- ✧ Bonding option for buzzer alarm frequency 4K/5.3K/6.4K/8KHz
- ✧ Bonding option for °C and °F
- ✧ Bonding option for °C/°F changeable or not change mode by pushing switch
- ✧ When °C/°F changeable mode, push ON/OFF button to select °C/°F and bonding option °C or °F when power on initial

.Block Diagram:

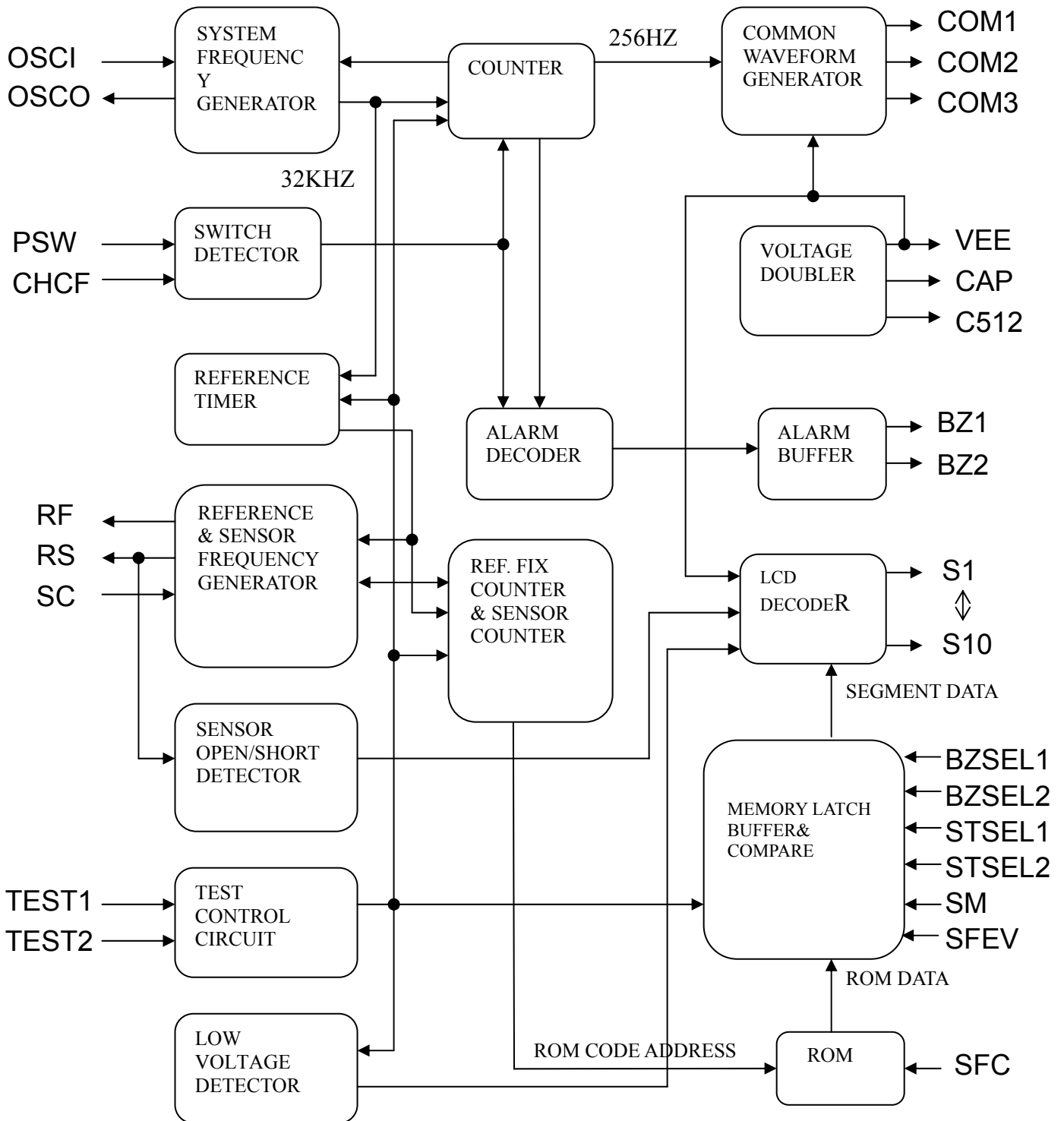

TTP301A/TTP301B

.Pad Description:

Pad No.	Pad Name	I/O	Description																		
1~10	S1~S10	O	LCD segment driver, connect to LCD																		
11	VEE	O	Generated 3V voltage																		
12	CAP	O	For positive voltage pumping																		
13	C512	O	For positive voltage pumping																		
14	TEST1	I	Test pad, for IC test only																		
15	SFC	I	Bonding option for °C or °F mode SFC= VDD or Open: °C (When °C/°F change mode, power on is °C) SFC= VSS: °F (When °C/°F change mode, power on is °F)																		
16	CHCF	I	Bonding option for °C/°F changeable or not changeable mode CHCF= VDD or Open: °C/°F not changeable mode CHCF= VSS: °C/°F changeable mode																		
17	NC																				
18	VSS	P	Negative power supply																		
19	SC	I/O	Reference and sensor frequency pad.																		
20	RF	O	Connect to reference resistor																		
21	RS	O	Connect to sensor resistor																		
22	VDD	P	Positive power supply																		
23	PSW	I	Pull high input pad, push switch to power on or power off																		
24	TEST2	I	Pull high input pad, for the test of production TEST2= VDD or Open: LCD display the highest value TEST2= VSS: LCD display the real time value																		
25 26	BZSEL1 BZSEL2	I I	<table border="1" style="width: 100%; border-collapse: collapse;"> <thead> <tr> <th colspan="3">Pull high input pad, bonding option for buzzer output frequency</th> </tr> <tr> <th>BZ FREQ.</th> <th>BZSEL1</th> <th>BZSEL2</th> </tr> </thead> <tbody> <tr> <td>8.0KHz</td> <td>VDD or Open</td> <td>VDD or Open</td> </tr> <tr> <td>6.4KHz</td> <td>VSS</td> <td>VDD or Open</td> </tr> <tr> <td>5.3KHz</td> <td>VDD or Open</td> <td>VSS</td> </tr> <tr> <td>4.0KHz</td> <td>VSS</td> <td>VSS</td> </tr> </tbody> </table>	Pull high input pad, bonding option for buzzer output frequency			BZ FREQ.	BZSEL1	BZSEL2	8.0KHz	VDD or Open	VDD or Open	6.4KHz	VSS	VDD or Open	5.3KHz	VDD or Open	VSS	4.0KHz	VSS	VSS
Pull high input pad, bonding option for buzzer output frequency																					
BZ FREQ.	BZSEL1	BZSEL2																			
8.0KHz	VDD or Open	VDD or Open																			
6.4KHz	VSS	VDD or Open																			
5.3KHz	VDD or Open	VSS																			
4.0KHz	VSS	VSS																			
27 28	STSEL1 STSEL2	I I	<table border="1" style="width: 100%; border-collapse: collapse;"> <thead> <tr> <th colspan="3">Pull high input pad, bonding option for stable time</th> </tr> <tr> <th>Stable time</th> <th>STSEL1</th> <th>STSEL2</th> </tr> </thead> <tbody> <tr> <td>16 sec</td> <td>VDD or Open</td> <td>VDD or Open</td> </tr> <tr> <td>4 sec</td> <td>VSS</td> <td>VDD or Open</td> </tr> <tr> <td>8 sec</td> <td>VDD or Open</td> <td>VSS</td> </tr> <tr> <td>32 sec</td> <td>VSS</td> <td>VSS</td> </tr> </tbody> </table>	Pull high input pad, bonding option for stable time			Stable time	STSEL1	STSEL2	16 sec	VDD or Open	VDD or Open	4 sec	VSS	VDD or Open	8 sec	VDD or Open	VSS	32 sec	VSS	VSS
Pull high input pad, bonding option for stable time																					
Stable time	STSEL1	STSEL2																			
16 sec	VDD or Open	VDD or Open																			
4 sec	VSS	VDD or Open																			
8 sec	VDD or Open	VSS																			
32 sec	VSS	VSS																			
29	SM	I	Pull high input pad, bonding option for memory function SM= VDD or Open: non-memory function SM= VSS: With memory function. After LCD full display, display the last measuring temperature.																		
30	SFEV	I	Pull high input pad, bonding option for fever alarm function SFEV= VDD or Open: With fever function SFEV= VSS: non-fever function																		
31	OSCI	I	System oscillator input pad																		
32	OSCO	O	System oscillator output pad																		
33	BZ1	O	Buzzer output pad 1																		
34	BZ2	O	Buzzer output pad 2																		
35~37	COM1~COM3	O	LCD common driver, connect to LCD																		

TTP301A/TTP301B

.Electrical Parameter:

Description		Max.	Typical	Min.
1. Operating Voltage:		1.65V	1.5V	1.25V
2. Operating Average Current:		50uA	20uA	
3. Input Voltage:	VIL	V _{ss} +0.3V		
	VIH			V _{dd} -0.3V
4. Output Voltage:	VOL	V _{ss} +0.1V		
	VOH			V _{dd} -0.1V
5. Buzzer Driving Current :(V _{ds} =1/2 V _{dd})				1mA
6. Buzzer Sinking Current:(V _{ds} =1/2 V _{dd})				1mA
7. Pull-high Resistor: PSW Pad			250K Ω	
8. Pull-high Resistor: TEST2, SFC, CHCF, BZSEL1, BZSEL2, STSEL1, STSEL2, SM, SFEV Pad			25K Ω	

.Function Description:

- <1> Power SW: Push PSW switch to power on or power off.
- <2> When power on: push the switch, a “BI” sound for 0.125 sec will be generated.
- A. The LCD display 188.8°M about 2 sec. If non-memory function the “M” mark will not display.
- B. After A,
- B-1. When **CHCF= VDD or Open(°C/°F is not changeable mode by pushing switch)**:
When the memory function is optioned (SM=VSS). The LCD displays the last measuring temperature and “M” mark about 2 sec.
If it is selected non-memory function (SM=NC or VDD), then jump to the step C.
- B-2. When **CHCF= VSS(°C/°F is changeable mode by pushing switch)**:
If push switch over 2 sec, the °C/°F mode will be changed to another mode and only display °C (or °F) until release switch. And then the LCD displays the Lo °C (or Lo °F) and “M” mark about 2 sec, when the memory function is optioned (SM=VSS). Another that is selected non-memory function (SM=NC or VDD), and then jump to the step C.
- C. After B, LCD displays the self-test temperature (37.0°C/98.6°F) about 1 sec.
The °C/°F mark will start to flash at the speed of 1Hz and starts to count the stable time.
- D. After C, it will start to measure temperature and the °C/°F mark flash at the speed of 1Hz. The LCD always displays the highest measuring temperature.
- E. If the temperature < 32.0°C (or 90.0°F), the LCD displays Lo °C (or Lo °F).
- F. If the temperature \geq 43.0°C (or 110.0°F), the LCD displays Hi °C (or Hi °F).
- G. When measuring, the LCD will always display the highest temperature.
- H. If the measure temperature does not change within the stable time, the measurement will be over and the °C(°F) mark flash stop.
- I. When measurement is over and if the temperature \geq 37.8 °C (100.0 °F),
the buzzer will alarm “BI—BI—BI———BI—BI—BI———” for 10 sec, as follows:
BI—BI—BI———BI—
BI: 0.125sec
—: 0.125sec
———: 0.375sec
- If the temperature < 37.8 °C (100.0 °F), the buzzer will alarms “BI—BI—BI—BI—” for 10 sec,
as follows:
BI—BI—
BI: 0.5sec
—: 0.5sec
- J. It will automatically power off after measurement is stable and the system is still on more than 8 min 40 sec (Fsys=32768Hz).
- K. When measurement is over and the beep sound is terminated, if the temperature rises within 8 min 40 sec, the measurement will start again, but the °C (°F) mark will not flash and the buzzer will not output also.
- L. During BI sound is on 10 sec and delay 2 sec, the temperature is not measurement.
- <3> When power off: the stand-by current \leq 1uA.
- <4> Measurement to 0.1 degree at °C or °F.
- <5> Sensor use 503ET.
- <6> Reference resistor is the value sensor in 37.0 °C.

TTP301A/TTP301B

- <7> When battery voltage is low, the battery mark "■" will flash at the speed of 1Hz.
And the measurement maybe not accurate, it means thermometer must be changed battery.
The low voltage detect: (TTP301A : $1.30 \pm 0.05V$; TTP301B : $1.35 \pm 0.05V$).
- <8> When TEST2 pin is connected to VSS, the LCD will display the real-time value not the highest value, in order to adjust the reference resistance RF during the process of producing.
The LCD can be up or down changed, not always display the highest value.
- <9> When sensor circuit detect error, LCD only display "Err" , it will not measure normally until the error status cancel.
- <10> The frequency of buzzer is selected by BZSEL1 and BZSEL2 pads option.

Buzzer frequency	BZSEL1	BZSEL2
8.0KHz	VDD or Open	VDD or Open
6.4KHz	VSS	VDD or Open
5.3KHz	VDD or Open	VSS
4.0KHz	VSS	VSS

- <11> The 4 kinds of stable time are 4 sec, 8 sec, 16 sec and 32 sec to be selected by STSEL1 and STSEL2 pads option.

Stable Time	STSEL1	STSEL2
16 sec	VDD or Open	VDD or Open
4 sec	VSS	VDD or Open
8 sec	VDD or Open	VSS
32 sec	VSS	VSS

- <12> °C/°F power on initial function is used SFC pad option.

Mode	SFC
°C	VDD or Open
°F	VSS

- <13> °C/°F changeable or not changeable mode is used CHCF pad option.

	CHCF
Not changeable mode	VDD or Open
Changeable mode	VSS

- <14> Memory function is used SM pad option.

	SM
Non-memory function	VDD or Open
With memory function	VSS

- <15> Fever function is used SFEV pad option.

	SFEV
With fever function	VDD or Open
Non-fever function	VSS

- <16> Thermometer others character is below:

temperature range	32.0°C ~ 42.9°C	90.0°F ~ 109.9°F
accuracy	±0.1 °C	±0.2 °F
resolution	0.1 °C	0.1 °F

.LCD pattern

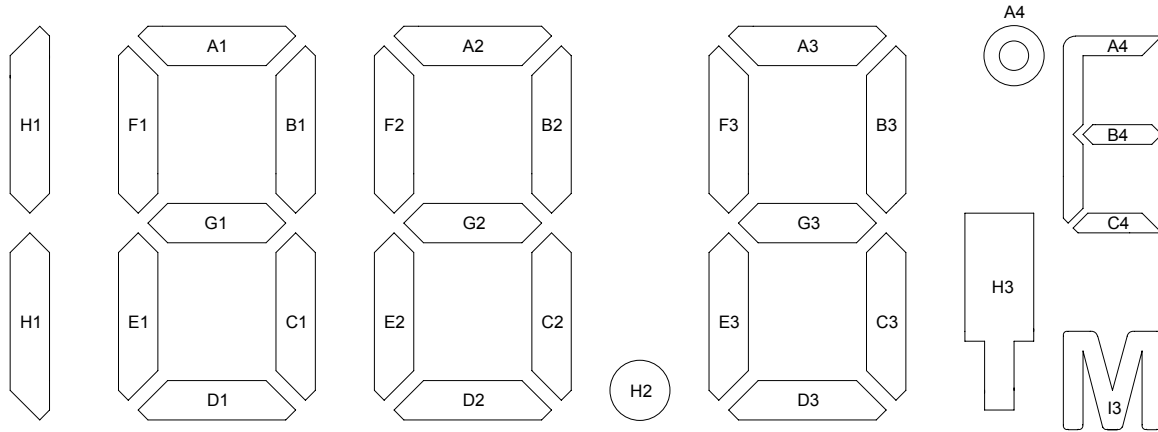

TTP301 PIN NAME	COM1	COM2	COM3	S1	S2	S3	S4	S5	S6	S7	S8	S9	S10
	1	2	3	4	5	6	7	8	9	10	11	12	13
COM1	COM1			F1	A1	B1	F2	A2	B2	F3	A3	B3	A4
COM2		COM2		E1	G1	C1	E2	G2	C2	E3	G3	C3	B4
COM3			COM3	H1	D1			D2	H2	I3	D3	H3	C4

SPEC : A . 1/3 DUTY , 1/2 BIAS . (LCD USES 3 V)

B . $V_{TH} = 1.5 V$

.Application Circuit

TTP301A/TTP301B APPLICATION CIRCUIT

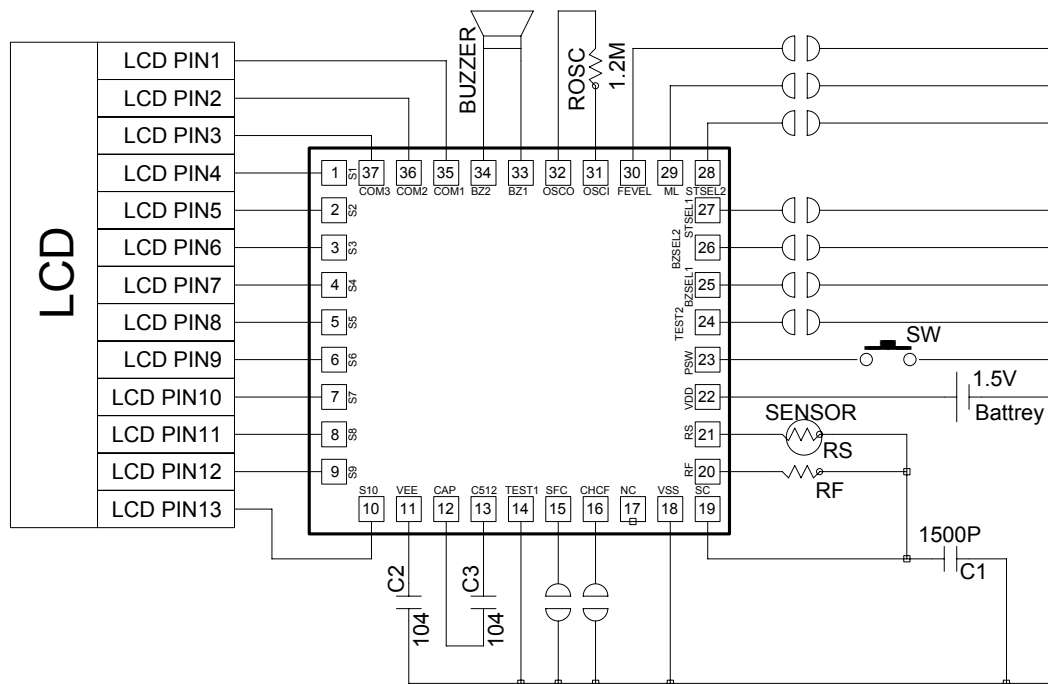

REMARK :

1. Sensor use ET-503 sensor.
2. RF is selected according to sensor type, RF resistor is the value of sensor ET-530 in 37.0°C.
3. Option table:

SFC PAD	°C/°F MODE
VDD or Open	°C Mode
VSS	°F Mode

CHCF PAD	°C/°F MODE
VDD or Open	Not Changeable Mode
VSS	Changeable Mode

BZSEL1 PAD	BZSEL2 PAD	Buzzer Frequency
VDD or Open	VDD or Open	8.0KHz
VSS	VDD or Open	6.4KHz
VDD or Open	VSS	5.3KHz
VSS	VSS	4.0KHz

STSEL1 PAD	STSEL2 PAD	Stable Time
VDD or Open	VDD or Open	16sec
VSS	VDD or Open	4sec
VDD or Open	VSS	8sec
VSS	VSS	32sec

SM PAD	VDD or Open	VSS
Function	Non-Memory	With Memory

7.

SFEV PAD	VDD or Open	VSS
Function	With Fever	Non-Fever

.PAD Location

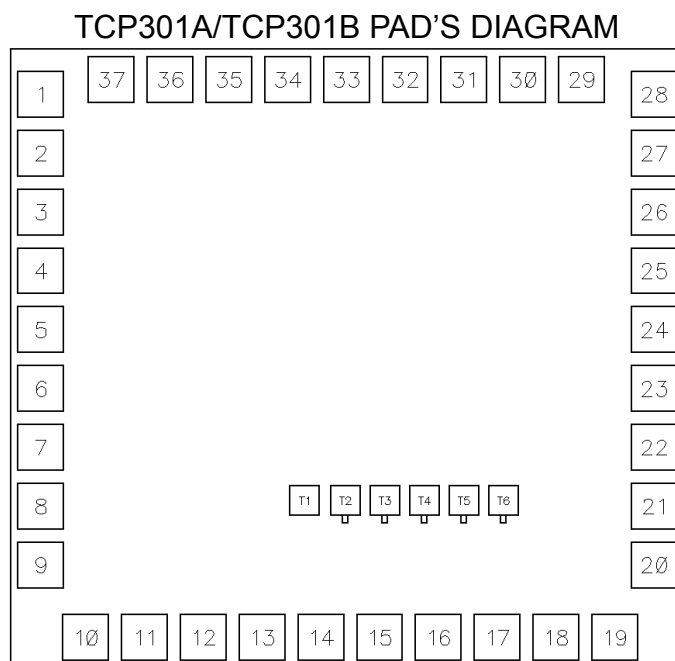

CHIP SIZE = 1410 X 1300 um²
 SUBSTRATE floating (recommmend) or VSS

PAD'S COORDINATE

Pad No.	Pad Name	X	Y	Pad No.	Pad Name	X	Y
1	S1	-605.00	520.80	20	RF	605.00	-407.20
2	S2	-605.00	404.80	21	RS	605.00	-291.20
3	S3	-605.00	288.80	22	VDD	605.00	-175.20
4	S4	-605.00	172.80	23	PSW	605.00	-59.20
5	S5	-605.00	56.80	24	TEST2	605.00	56.80
6	S6	-605.00	-59.20	25	BZSEL1	605.00	172.80
7	S7	-605.00	-175.20	26	BZSEL2	605.00	288.80
8	S8	-605.00	-291.20	27	STSEL1	605.00	404.80
9	S9	-605.00	-407.20	28	STSEL2	605.00	520.80
10	S10	-516.60	-550.00	29	SM	462.05	550.00
11	VEE	-400.60	-550.00	30	SFEV	346.05	550.00
12	CAP	-284.60	-550.00	31	OSCI	230.05	550.00
13	C512	-168.60	-550.00	32	OSCO	114.05	550.00
14	TEST1	-52.60	-550.00	33	BZ1	-1.95	550.00
15	SFC	63.40	-550.00	34	BZ2	-117.95	550.00
16	CHCF	179.40	-550.00	35	COM1	-233.95	550.00
17	NC	295.40	-550.00	36	COM2	-349.95	550.00
18	VSS	411.40	-550.00	37	COM3	-465.95	550.00
19	SC	527.40	-550.00				

.Function Flow Chart:

